

CONTROL BOX CB14

Features:

- Choice of 11 different standard software packages
- Connection of up to 5 system actuators with jack plug e.g. LA32 & LA28S
- Mains voltage: 220-240/120/100 V AC, 50-60 Hz
- Duty cycle: Max. 10% or 6 min./hour in continuous use
- Output voltage: 24 V DC
- Ambient temperature +5° to +40° C
- Protection class: IP 51
- Exchangeable 3.2 m straight mains cable
- Medically approved according to EN 60601-1
- Individual electronic overload protection (EOP)
- Compact high-power transformer with low power consumption and low electromagnetic emission
- Energy saving function (the control box defaults into a stand-by mode when not operated) (no discharging of the batteries in stand-by mode)
- Locking mechanism for DIN-, jack and mains socket
- Class 2 protection
- Colour: black
- LED for power indication
- EAS electronic overload protection of relays for extended life.

Options:

- Customised software can be ordered (required for LA34R)
- Protection against single fault condition when used together with ACP-box (only with special customised software)
- Mains fuse replaceable from the outside
- Extra fuse placed inside the lid.
- 0.6 m coiled mains cable
- Battery back-up: available with internally or externally fitted battery sets (BA18) (1.2 Ah) (audio battery alarm indicates low battery charge)
- Protection class: IP 66 for wash tunnels
- Class 1 (Earth connection outside the control box and 3-wire mains cable)
- Audio alarm warns when there is water inside the control box
- Colour: Grey
- 2 DIN socket for connection of 1 handset HB40E/HB50E/HB70E/DP1M/DPXE and 1 ACP-box (only with special software)



MEDLINE
IMPROVING EFFICIENCY
TECHLINE
IMPROVING FLEXIBILITY

The CB14 with microprocessor is developed for systems with a need to run up to five actuators or two actuators / lifting columns in parallel and / or with memory function.

The effective toroidal transformer and the many features such as battery back-up, earth outlet, wet alarm makes the control box suitable for a variety of applications.

CB14 is available in IP 66 and with special software compatible with an ACP box, which makes it the perfect choice for advanced hospital beds with special software.

The many features and options of the control box makes it furthermore ideal for computer and work stations, working tables, desks and other applications where programming or parallel drive is needed.

CB14

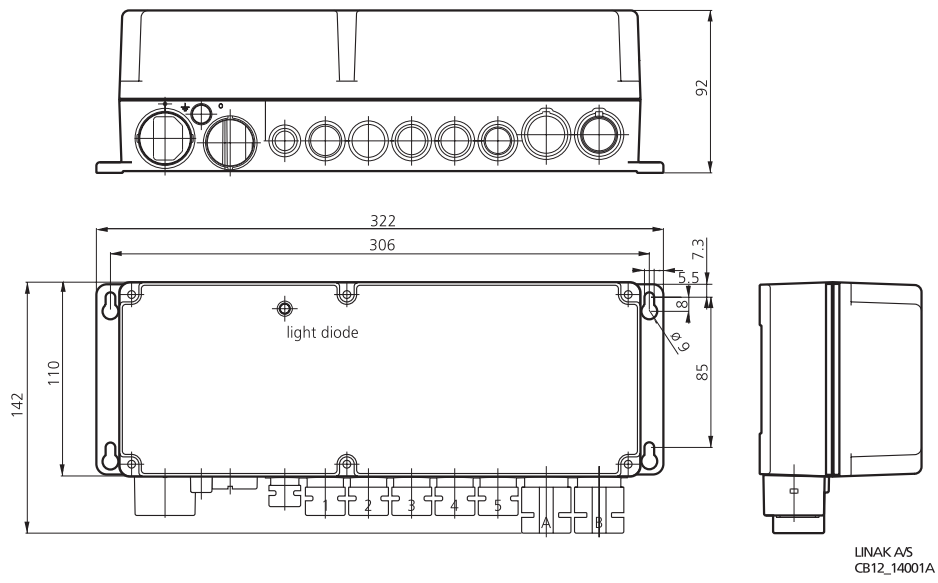

BA18

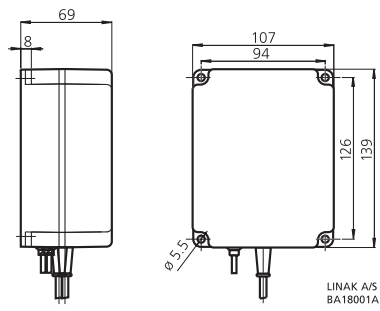

CB14 HOMELINE

Ordering example:

CB14 M 0 00 2 0 0 0 0 0 0

- Cables:**
- Mains cable 2P:**
- | | | | | |
|--------------------------|--------------|---------|-------------|---------|
| 0 = Straight cable EU | Black | 0015185 | Grey | 0015196 |
| 1 = Coiled cable EU | | 0015186 | | 0015197 |
| 3 = Straight cable UK | | 0015193 | | |
| 4 = Straight cable Japan | | 0015192 | | 0015253 |
| 5 = Straight cable UL | | 0015194 | | |
| 6 = Straight cable CH | | 0015536 | | |
| 7 = Straight cable AUS | | 0015239 | | |
| 9 = Without cable | | | | |
- Mains cable 3P with earth:**
- | | | | | |
|------------------------|--------------|---------|-------------|---------|
| A = Straight cable EU | Black | 0015183 | Grey | 0015184 |
| B = Coiled cable EU | | 0015191 | | 0015198 |
| D = Straight cable UK | | 0015275 | | |
| F = Straight cable UL | | 0015195 | | |
| G = Straight cable CH | | 0015242 | | |
| H = Straight cable AUS | | 0015241 | | |
| J = without cable | | | | |
| K = Coiled cable DK | | | | 0015250 |
- IP protection:** 0 = IP51
2 = IP66
- Mains voltage:** 0 = 230V 3 = 230V without fuse cover
1 = 120V 4 = 120V without fuse cover
2 = 100V 5 = 100V without fuse cover
- Colour:** 0 = Black
1 = Grey
- Option:** 0 = No ACP connection
A = ACP connection (only special article)
- Battery:** 0 = Ot
A = AT prepared for internal batteries (BA1200 to be ordered separately)
B = AT prepared for external batteries
C = At internal batteries + wet alarm (BA 1200 to be ordered separately)
D = AT external batteries + wet alarm
- Channels:** 1 - 5 (Max. current pr. channel = 5.5A - Max. total current = 10A)
- Option:** 0 = Standard
- Mains:** 0 = Standard
- Software:**

Name	Function	Memory with HB5xE (max. HB54E), HB7XW (max. HB73W)	Memory with DP1M	Memory with impulse push with HB5xE (max. HB54E)	Memory with impulse push with DP1M	Operation without memory with HB4xE, DPxE, HB7xE or FSXE
CB14A	2 channels parallel operation on CH1 and CH2			Yes	Yes	Yes
CB14B	Memory on all channels			Yes	Yes	Yes
CB14I	2+2 channels parallel operation on CH1 and CH2 as well as CH3 and CH4	Yes				Yes
CB14J	2+2 channels parallel operation on CH1 and CH2 as well as CH3 and CH4			Yes		Yes
CB14L	2 channels parallel operation on CH1 and CH2, Trendelenburg on CH1 and CH2	Yes	Yes			Yes
CB14M	Memory on all channels	Yes	Yes			Yes
CB14P	2 channels parallel operation on CH1 and CH2	Yes	Yes			Yes
CB140	Analogue control on all channels. Simultaneous operation on Trendelenburg with special handset possible					Yes

Type: Control box CB14

Wet-alarm only with AT-version
Earth only on 3P mains cable.



Standard software: All software packages have memory. To use memory a handset with memory functions must be ordered.

All actuators used together with CB14 have to be with reed switch (position feedback) except CB140 where the actuator must be without reed switch.

Actuators with end-stop switches must have special software

Specifications subject to change without prior notice.
It is the responsibility of the product user to determine the suitability of LINAK A/S products for a specific application. LINAK will at point of delivery replace/repair defective products covered by the warranty if promptly returned to the factory. No liability is assumed beyond such replacement/repair.